

Review Problems for Exam 1

1. **Two–Compartment Pharmacokinetic Modeling.** The flow diagram in Figure 1 depicts the flow of a drug in the amount $x(t)$ in the blood of a patient and in the amount $y(t)$ in the tissues. Drug is administered to the patient intravenously at a rate $R(t)$. The medication is then transferred from the blood compartment to the tissues compartment at a rate proportional to the amount of drug in the blood; it is also transferred back from the tissues compartment to the blood compartment also at a rate proportional to the amount of medication in the tissues (see the arrows in the diagram and the corresponding constants of proportionality). Medication can also leave the compartments through flushing out of the blood compartment or by chemical breakdown in the blood and tissues.

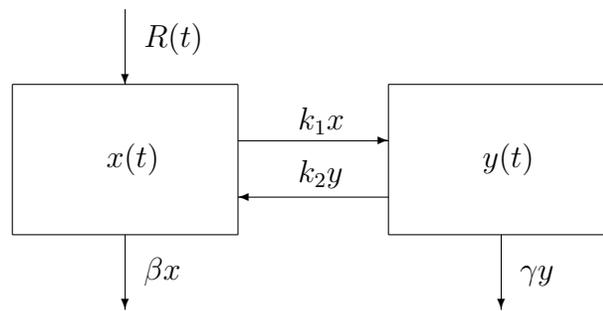

Figure 1: Two–Compartment Flow Diagram

- (a) Apply conservation principles to derive a mathematical model that describes the evolution of the quantities x and y in time.
- (b) Write the system obtained in part (a) above in vector form. Is the system linear? (Explain your reasoning). Is the system autonomous? (Explain your reasoning).
2. **A One–Compartment Dilution Model.** When people smoke, carbon monoxide is released into the air. Suppose that in a room of volume 60 m^3 , air containing 5% carbon monoxide is introduced at a rate of $0.002 \text{ m}^3/\text{min}$. (This means that 5% of the volume of incoming air is carbon monoxide). Assume

that the carbon monoxide mixes immediately with the air and that the mixture leaves the room at the same rate as it enters.

- (a) Let $Q = Q(t)$ denote the volume (in cubic meters) of carbon monoxide in the room at any time t in minutes. Use a conservation principle to write down a differential equation for Q .
 - (b) Based on your answer to part (a), give a differential equation satisfied by the concentration, $c(t)$, of carbon monoxide in the room (in percent volume) at any time t in minutes.
 - (c) Construct solutions of the differential equation that you derived in part (b). Based on your answer, what is the limiting value of $c(t)$ as $t \rightarrow \infty$?
 - (d) Medical texts warn that exposure to air containing 0.1% carbon monoxide for some time can lead to a coma. How many hours does it take for the concentration of carbon monoxide found in part (c) to reach this level? Assume that there is no carbon monoxide in the room at time $t = 0$.
3. **A One-Compartment Pharmacokinetic Model.** A patient is given the drug theophylline intravenously at a constant rate of 43.2 mg/hour to relieve acute asthma. You can imagine the drug as entering a compartment of volume 35,000 ml. (This is an estimate of the volume of the part of the body through which the drug circulates.) The rate at which the drug leaves the patient is proportional to the quantity there, with proportionality constant 0.082.
- (a) Use a conservation principle to derive a differential equation for the quantity, $Q = Q(t)$, in milligrams, of the drug in the body at time t hours.
 - (b) Construct solutions to the differential equation derived in part (a).
 - (c) Based on your answer in part (b), what is the limiting value of $Q(t)$ as $t \rightarrow \infty$?
4. Construct solutions of the linear, first order differential equation

$$\frac{dy}{dt} = 2ty + t.$$

5. For the following linear system, give the equations for the solution curves and sketch the phase portrait.

$$\begin{cases} \dot{x} &= -3x + y; \\ \dot{y} &= -x - 3y. \end{cases}$$

What happens to the solutions as $t \rightarrow \infty$?

6. For the following linear system, give the equations for the solution curves and sketch the phase portrait.

$$\begin{cases} \dot{x} &= 2y; \\ \dot{y} &= x + y. \end{cases}$$

Construct a solution of the system subject to the initial condition: $x(0) = 1$, $y(0) = 1$.

7. Construct solutions of the second order differential equation

$$\frac{d^2x}{dt^2} + x = 0. \tag{1}$$

Give a solution of (1) subject to the initial conditions $x(0) = 1$, $x'(0) = 0$.

8. Construct solutions of the linear system

$$\begin{cases} \dot{x} &= x - 4y; \\ \dot{y} &= 4x - 7y. \end{cases}$$

Use nullclines to sketch the phase portrait.

9. Let u and v be two nonnegative continuous functions defined on some open interval J which contains t_o and that

$$u(t) \leq M + \int_{t_o}^t v(\tau)u(\tau) \, d\tau$$

for all $t \in J$ and some nonnegative constant M . Show that

$$u(t) \leq M e^{\int_{t_o}^t v(\tau) \, d\tau} \quad \text{for all } t \in J.$$

(*Suggestion:* Let $\varphi(t) = M + \int_{t_o}^t v(\tau)u(\tau) \, d\tau$ and show that φ is a solution to certain initial value problem for a linear first order equation.)