

## Solutions to Review Problems for Exam 1

1. **Two-Compartment Pharmacokinetic Modeling.** The flow diagram in Figure 1 depicts the flow of a drug in the amount  $x(t)$  in the blood of a patient and in the amount  $y(t)$  in the tissues. Drug is administered to the patient intravenously at a rate  $R(t)$ . The medication is then transferred from the blood compartment to the tissues compartment at a rate proportional to the amount of drug in the blood; it is also transferred back from the tissues compartment to the blood compartment also at a rate proportional to the amount of medication in the tissues (see the arrows in the diagram and the corresponding constants of proportionality). Medication can also leave the compartments through flushing out of the blood compartment or by chemical breakdown in the blood and tissues.

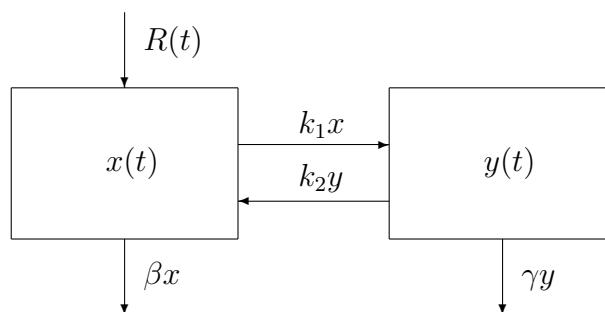

Figure 1: Two-Compartment Flow Diagram

- (a) Apply conservation principles to derive a mathematical model that describes the evolution of the quantities  $x$  and  $y$  in time.

**Solution:** Apply the conservation principle to the  $x$ -compartment,

$$\frac{dx}{dt} = \text{Rate of } x \text{ in} - \text{Rate of } x \text{ out},$$

where

$$\text{Rate of } x \text{ in} = R(t) + k_2 y$$

and

$$\text{Rate of } x \text{ out} = k_1 x + \beta x;$$

so that,

$$\frac{dx}{dt} = R(t) + k_2y - (k_1x + \beta x),$$

or

$$\frac{dx}{dt} = R(t) - (k_1 + \beta)x + k_2y. \quad (1)$$

Next, apply the conservation principle

$$\frac{dy}{dt} = \text{Rate of } y \text{ in} - \text{Rate of } y \text{ out}$$

to the  $y$ -compartment, where

$$\text{Rate of } y \text{ in} = k_1x$$

and

$$\text{Rate of } y \text{ out} = k_2y + \gamma y;$$

so that,

$$\frac{dy}{dt} = k_1x - (k_2y + \gamma y),$$

or

$$\frac{dy}{dt} = k_1x - (k_2 + \gamma)y. \quad (2)$$

Combining the equations in (1) and (2) we obtain the system

$$\begin{cases} \dot{x} = R(t) - (k_1 + \beta)x + k_2y; \\ \dot{y} = k_1x - (k_2 + \gamma)y. \end{cases} \quad (3)$$

□

- (b) Write the system obtained in part (b) above in vector form. Is the system linear? (Explain your reasoning). Is the system autonomous? (Explain your reasoning).

**Solution:** Writing the system in (3) in vector form we get

$$\begin{pmatrix} \dot{x} \\ \dot{y} \end{pmatrix} = \begin{pmatrix} R(t) - (k_1 + \beta)x + k_2y \\ k_1x - (k_2 + \gamma)y \end{pmatrix},$$

or

$$\begin{pmatrix} \dot{x} \\ \dot{y} \end{pmatrix} = \begin{pmatrix} -(k_1 + \beta)x + k_2y \\ k_1x - (k_2 + \gamma)y \end{pmatrix} + \begin{pmatrix} R(t) \\ 0 \end{pmatrix},$$

or

$$\begin{pmatrix} \dot{x} \\ \dot{y} \end{pmatrix} = \begin{pmatrix} -(k_1 + \beta) & k_2 \\ k_1 & -(k_2 + \gamma) \end{pmatrix} \begin{pmatrix} x \\ y \end{pmatrix} + \begin{pmatrix} R(t) \\ 0 \end{pmatrix},$$

or

$$\begin{pmatrix} \dot{x} \\ \dot{y} \end{pmatrix} = A \begin{pmatrix} x \\ y \end{pmatrix} + \begin{pmatrix} R(t) \\ 0 \end{pmatrix},$$

where

$$A = \begin{pmatrix} -(k_1 + \beta) & k_2 \\ k_1 & -(k_2 + \gamma) \end{pmatrix}$$

is a  $2 \times 2$  matrix whose coefficients are independent of  $x$  and  $y$ . Hence, the system in (3) is a linear system.

If  $R(t)$  is constant, then the system in (3) is autonomous; otherwise, the system is non-autonomous.  $\square$

2. **A One-Compartment Dilution Model.** When people smoke, carbon monoxide is released into the air. Suppose that in a room of volume  $60 \text{ m}^3$ , air containing 5% carbon monoxide is introduced at a rate of  $0.002 \text{ m}^3/\text{min}$ . (This means that 5% of the volume of incoming air is carbon monoxide). Assume that the carbon monoxide mixes immediately with the air and that the mixture leaves the room at the same rate as it enters.

- (a) Let  $Q = Q(t)$  denote the volume (in cubic meters) of carbon monoxide in the room at any time  $t$  in minutes. Use a conservation principle to write down a differential equation for  $Q$ .

**Solution:** The diagram in Figure 2 depicts the room as a compartment of fixed volume  $V = 60$  cubic meters. Air flows into the compartment at

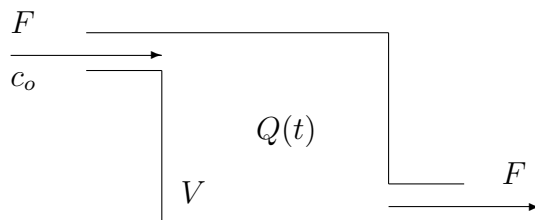

Figure 2: One-Compartment Model

a rate  $F = 0.002 \text{ m}^3/\text{min}$  and goes out of the chamber at the same rate  $F$ . The incoming air contains carbon monoxide (CO) at a concentration  $c_o = 5\%$  in units of percent volume.

Since we are assuming that the incoming CO mixes immediately with the air in the room, the concentration of CO in the room at time  $t$  is given by

$$c(t) = \frac{Q(t)}{V}, \quad \text{for all } t > 0. \quad (4)$$

Applying a conservation principle to the volume of CO in the room,  $Q(t)$ , at any time  $t$ , we have that

$$\frac{dQ}{dt} = \text{Rate of } Q \text{ in} - \text{Rate of } Q \text{ out},$$

where

$$\text{Rate of } Q \text{ in} = Fc_o$$

and

$$\text{Rate of } Q \text{ out} = Fc(t);$$

so that,

$$\frac{dQ}{dt} = Fc_o - F\frac{Q(t)}{V},$$

where we have used (4), or

$$\frac{dQ}{dt} = Fc_o - \frac{F}{V}Q. \quad (5)$$

□

- (b) Based on your answer to part (a), give a differential equation satisfied by the concentration,  $c(t)$ , of carbon monoxide in the room (in percent volume) at any time  $t$  in minutes.

**Solution:** Divide the differential equation in (5) by  $V$  and use (4), where  $V$  is constant to obtain,

$$\frac{dc}{dt} = \frac{F}{V}c_o - \frac{F}{V}c. \quad (6)$$

□

- (c) Construct solutions of the differential equation that you derived in part (b). Based on your answer, what is the limiting value of  $c(t)$  as  $t \rightarrow \infty$ ?

**Solution:** We can solve the differential equation in (6) using an integrating factor.

Rewrite the equation in (6) as

$$\frac{dc}{dt} + \frac{F}{V}c = \frac{F}{V}c_o,$$

and multiply by the integrating factor

$$\mu(t) = e^{\frac{F}{V}t} \quad (7)$$

to get

$$\mu(t) \frac{dc}{dt} + \frac{F}{V} \mu(t) c = \frac{F}{V} c_o e^{\frac{F}{V}t},$$

or

$$\frac{d}{dt} [\mu(t)c] = \frac{F}{V} c_o e^{\frac{F}{V}t}. \quad (8)$$

Integrate on both sides of (8) with respect to  $t$  to get

$$\mu(t)c(t) = c_o e^{\frac{F}{V}t} + k, \quad (9)$$

where  $k$  is a constant of integration.

Divide on both sides of the the equation in (9) by  $\mu(t)$  given in (7) to get

$$c(t) = c_o + k e^{-\frac{F}{V}t}, \quad \text{for all } t \geq 0. \quad (10)$$

Letting  $t \rightarrow \infty$  in (10) we obtain that

$$\lim_{t \rightarrow \infty} c(t) = c_o,$$

since  $F$  and  $V$  are positive constants. □

- (d) Medical texts warn that exposure to air containing 0.1% carbon monoxide for some time can lead to a coma. How many hours does it take for the concentration of carbon monoxide found in part (c) to reach this level? Assume that there is no carbon monoxide in the room at time  $t = 0$ .

**Solution:** Assuming that there is no CO in the room at time  $t = 0$ , we get from (4) that  $c(0) = 0$ ; thus, using (10) we obtain that  $c_o + k = 0$ , from which we get that  $k = -c_o$ . Hence, substituting this value for  $k$  into (10),

$$c(t) = c_o \left(1 - e^{-\frac{F}{V}t}\right), \quad \text{for all } t \geq 0. \quad (11)$$

We are asked to find a time  $t$  such that  $c(t) = 0.1\%$ , or according to (11),

$$0.05 \left(1 - e^{-\frac{F}{V}t}\right) = 0.001,$$

or, after multiplying on both sides by 1,000,

$$50 \left(1 - e^{-\frac{F}{V}t}\right) = 1. \quad (12)$$

Solving the equation in (12) for  $t$  yields

$$t = \frac{V}{F} \ln \left( \frac{50}{49} \right). \quad (13)$$

Next, substitute the values  $F = 0.002 \text{ m}^3/\text{min}$  and  $V = 60 \text{ m}^3$  in (13) to obtain,

$$t = 30,000 \ln \left( \frac{50}{49} \right) \text{ min},$$

or about 606 minutes, or about 10 hours. □

3. **A One-Compartment Pharmacokinetic Model.** A patient is given the drug theophylline intravenously at a constant rate of 43.2 mg/hour to relieve acute asthma. You can imagine the drug as entering a compartment of volume 35,000 ml. (This is an estimate of the volume of the part of the body through which the drug circulates.) The rate at which the drug leaves the patient is proportional to the quantity there, with proportionality constant 0.082.

- (a) Use a conservation principle to derive a differential equation for the quantity,  $Q = Q(t)$ , in milligrams, of the drug in the body at time  $t$  hours.

**Solution:** The diagram in Figure 3 shows the compartment with theophylline entering the compartment at a rate  $r = 43.2 \text{ mg/hour}$  and leaving the compartment at a rate  $kQ$ , with  $k = 0.082 \text{ hour}^{-1}$ .

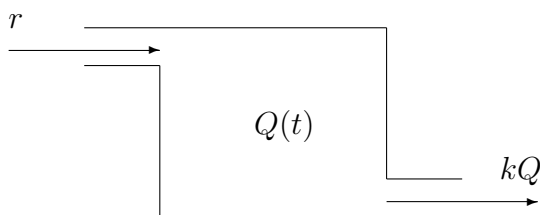

Figure 3: One-Compartment Model

Applying a conservation principle to the amount of theophylline,  $Q(t)$ , in milligrams, at any time  $t$ , we have that

$$\frac{dQ}{dt} = \text{Rate of } Q \text{ in} - \text{Rate of } Q \text{ out},$$

where

$$\text{Rate of } Q \text{ in} = r$$

and

$$\text{Rate of } Q \text{ out} = kQ;$$

so that,

$$\frac{dQ}{dt} = r - kQ. \quad (14)$$

□

(b) Construct solutions to the differential equation derived in part (a).

**Solution:** We can solve the differential equation in (14) using an integrating factor.

Rewrite the equation in (14) as

$$\frac{dQ}{dt} + kQ = r,$$

and multiply by the integrating factor

$$\mu(t) = e^{kt}$$

to get

$$e^{kt} \frac{dQ}{dt} + ke^{kt}Q = re^{kt},$$

or

$$\frac{d}{dt} [e^{kt}Q] = re^{kt}. \quad (15)$$

Integrate on both sides of (15) with respect to  $t$  to get

$$e^{kt}Q(t) = \frac{r}{k}e^{kt} + C, \quad (16)$$

where  $C$  is a constant of integration.

Divide on both sides of the equation in (16) by  $e^{kt}$  to obtain

$$Q(t) = \frac{r}{k} + Ce^{-kt}, \quad \text{for all } t. \quad (17)$$

□

(c) Based on your answer in part (b), what is the limiting value of  $Q(t)$  as  $t \rightarrow \infty$ ?

**Solution:** Let  $t \rightarrow \infty$  in (17) to obtain that

$$\lim_{t \rightarrow \infty} Q(t) = \frac{r}{k}, \quad (18)$$

since  $k$  is a positive constant. Using the values  $r = 43.2$  mg/hour and  $k = 0.082$  hour<sup>-1</sup>, in (18) we obtain that

$$\lim_{t \rightarrow \infty} Q(t) = \frac{43.2}{0.082} \text{ mg},$$

or about 527 milligrams. □

4. Construct solutions of the linear, first order differential equation

$$\frac{dy}{dt} = 2ty + t. \quad (19)$$

**Solution:** We can solve the differential equation in (19) using an integrating factor.

Rewrite the equation in (14) as

$$\frac{dy}{dt} - 2ty = t,$$

and multiply by the integrating factor

$$\mu(t) = e^{-t^2}$$

to get

$$e^{-t^2} \frac{dy}{dt} - 2te^{-t^2}y = te^{-t^2},$$

or

$$\frac{d}{dt} \left[ e^{-t^2} y \right] = te^{-t^2}. \quad (20)$$

Integrate on both sides of (20) with respect to  $t$  to get

$$e^{-t^2} y(t) = -\frac{1}{2} e^{-t^2} + C, \quad (21)$$

where  $C$  is a constant of integration.

Divide on both sides of the equation in (21) by  $e^{-t^2}$  to obtain

$$y(t) = -\frac{1}{2} + Ce^{t^2}, \quad \text{for all } t.$$

□



5. For the following linear system, give the equations for the solution curves and sketch the phase portrait.

$$\begin{cases} \dot{x} = -3x + y; \\ \dot{y} = -x - 3y. \end{cases} \quad (22)$$

What happens to the solutions as  $t \rightarrow \infty$ ?

**Solution:** Note that the system in (22) is of the form

$$\begin{cases} \dot{x} = \alpha x - \beta y; \\ \dot{y} = \beta x + \alpha y, \end{cases} \quad (23)$$

where  $\alpha = -3$  and  $\beta = -1$ . The general solution of the system in (23) is

$$\begin{pmatrix} x(t) \\ y(t) \end{pmatrix} = Re^{at} \begin{pmatrix} \cos(\beta t + \phi) \\ \sin(\beta t + \phi) \end{pmatrix}, \quad \text{for all } t \in \mathbb{R},$$

and for constants  $R \geq 0$  and  $\phi \in \mathbb{R}$ . Thus, the general solution of the system in (22) is

$$\begin{pmatrix} x(t) \\ y(t) \end{pmatrix} = Re^{-3t} \begin{pmatrix} \cos(-t + \phi) \\ \sin(-t + \phi) \end{pmatrix}, \quad \text{for all } t \in \mathbb{R}, \quad (24)$$

or

$$\begin{pmatrix} x(t) \\ y(t) \end{pmatrix} = Re^{-3t} \begin{pmatrix} \cos(t - \phi) \\ -\sin(t - \phi) \end{pmatrix}, \quad \text{for all } t \in \mathbb{R}.$$

According to (24), the trajectories of the system in (22) spiral in towards the origin in the clockwise sense. Some of these trajectories are sketched in Figure 4 on page 16. The sketch in Figure 4, obtained using pplane for java, also shows the nullclines of the system in (22).  $\square$

6. For the following linear system, give the equations for the solution curves and sketch the phase portrait.

$$\begin{cases} \dot{x} = 2y; \\ \dot{y} = x + y. \end{cases} \quad (25)$$

Construct a solution of the system subject to the initial condition:  $x(0) = 1$ ,  $y(0) = 1$ .

**Solution:** Write the system in (25) in vector form to get

$$\begin{pmatrix} \dot{x} \\ \dot{y} \end{pmatrix} = A \begin{pmatrix} x \\ y \end{pmatrix},$$

where  $A$  is the  $2 \times 2$  matrix

$$A = \begin{pmatrix} 0 & 2 \\ 1 & 1 \end{pmatrix}. \quad (26)$$

Next, we see whether or not the matrix  $A$  in (26) is diagonalizable.

The characteristic polynomial of  $A$  is

$$p_A(\lambda) = \lambda^2 - \lambda - 2,$$

which factors into

$$p_A(\lambda) = (\lambda + 1)(\lambda - 2).$$

Thus, the matrix  $A$  has distinct real eigenvalues

$$\lambda_1 = -1 \quad \text{and} \quad \lambda_2 = 2.$$

Thus,  $A$  is diagonalizable with a basis of eigenvectors

$$\mathbf{v}_1 = \begin{pmatrix} 2 \\ -1 \end{pmatrix} \quad \text{and} \quad \mathbf{v}_2 = \begin{pmatrix} 1 \\ 1 \end{pmatrix}, \quad (27)$$

corresponding to  $\lambda_1$  and  $\lambda_2$ , respectively.

Hence, the general solution of the system in (25) is given by

$$\begin{pmatrix} x(t) \\ y(t) \end{pmatrix} = c_1 e^{-t} \mathbf{v}_1 + c_2 e^{2t} \mathbf{v}_2, \quad (28)$$

where the vectors  $\mathbf{v}_1$  and  $\mathbf{v}_2$  are given in (27), and  $c_1$  and  $c_2$  are arbitrary constants.

A sketch of a few of the trajectories (28) is given in Figure 5 on page 17. The sketch also shows that direction field of the system and the particular solution

$$\begin{pmatrix} x(t) \\ y(t) \end{pmatrix} = e^{2t} \mathbf{v}_2, \quad (29)$$

that goes through the point  $\begin{pmatrix} x(0) \\ y(0) \end{pmatrix} = \mathbf{v}_2 = \begin{pmatrix} 1 \\ 1 \end{pmatrix}$ . This is a line solution in the direction of the vector  $\mathbf{v}_2$ .  $\square$

7. Construct solutions of the second order differential equation

$$\frac{d^2x}{dt^2} + x = 0. \quad (30)$$

Give a solution of (30) subject to the initial conditions  $x(0) = 1$ ,  $x'(0) = 0$ .

**Solution:** We turn the second-order differential equation into (30) into a two-dimensional system of first order equations by introducing a variable

$$y = \frac{dx}{dt}. \quad (31)$$

We then obtain from (31) that

$$\dot{x} = y. \quad (32)$$

We also obtain from (31) that

$$\dot{y} = \frac{d^2x}{dt^2};$$

so that, using (30),

$$\dot{y} = -x. \quad (33)$$

Combining (32) and (33) we obtain the system of differential equations

$$\begin{cases} \dot{x} = y; \\ \dot{y} = -x. \end{cases} \quad (34)$$

The system in (34) is of the form

$$\begin{cases} \dot{x} = \alpha x - \beta y; \\ \dot{y} = \beta x + \alpha y, \end{cases} \quad (35)$$

where  $\alpha = 0$  and  $\beta = -1$ . Thus, the general solution of the system in (34) is

$$\begin{pmatrix} x(t) \\ y(t) \end{pmatrix} = R \begin{pmatrix} \cos(-t + \phi) \\ \sin(-t + \phi) \end{pmatrix}, \quad \text{for all } t \in \mathbb{R},$$

for constants  $R \geq 0$  and  $\phi \in \mathbb{R}$ , or

$$\begin{pmatrix} x(t) \\ y(t) \end{pmatrix} = \begin{pmatrix} R \cos(t - \phi) \\ -R \sin(t - \phi) \end{pmatrix}, \quad \text{for all } t \in \mathbb{R}. \quad (36)$$

Picking our the first component of the vector in (36) yields

$$x(t) = R \cos(t - \phi), \quad \text{for all } t \in \mathbb{R}. \quad (37)$$

This is the general solution of the second-order differential equation in (30).

To find a particular solution of (30) satisfying the initial conditions  $x(0) = 1$ ,  $x'(0) = 0$ , use (37) to compute

$$x'(t) = -R \sin(t - \phi), \quad \text{for all } t \in \mathbb{R}. \quad (38)$$

We then obtain from (37), (38) and the initial conditions, that

$$\begin{cases} R \cos(-\phi) = 1; \\ -R \sin(-\phi) = 0, \end{cases}$$

or

$$\begin{cases} R \cos(\phi) = 1; \\ R \sin(\phi) = 0. \end{cases} \quad (39)$$

Solving the system in (39) simultaneously yields  $R = 1$  and  $\phi = 0$ . We then get from (37) that

$$x(t) = \cos(t), \quad \text{for all } t \in \mathbb{R}.$$

□

8. Construct solutions of the linear system

$$\begin{cases} \dot{x} = x - 4y; \\ \dot{y} = 4x - 7y. \end{cases} \quad (40)$$

Use nullclines to sketch the phase portrait.

**Solution:** Write the system in (40) in vector form to get

$$\begin{pmatrix} \dot{x} \\ \dot{y} \end{pmatrix} = A \begin{pmatrix} x \\ y \end{pmatrix},$$

where  $A$  is the  $2 \times 2$  matrix

$$A = \begin{pmatrix} 1 & -4 \\ 4 & -7 \end{pmatrix}. \quad (41)$$

Next, we see whether or not the matrix  $A$  in (41) is diagonalizable.

The characteristic polynomial of  $A$  is

$$p_A(\lambda) = \lambda^2 + 6\lambda + 9,$$

which factors into

$$p_A(\lambda) = (\lambda + 3)^2.$$

Thus, the matrix  $A$  has only one real eigenvalues

$$\lambda = -3. \tag{42}$$

The eigenspace corresponding to the eigenvalue  $\lambda$  given in (42) is one dimensional; hence,  $A$  is not diagonalizable. We can, however, turn  $A$  into the Jordan canonical form

$$J = \begin{pmatrix} \lambda & 1 \\ 0 & \lambda \end{pmatrix}$$

by a change of basis given by  $\{v_1, v_2\}$ , where

$$v_1 = \begin{pmatrix} 1 \\ 1 \end{pmatrix} \tag{43}$$

is an eigenvector corresponding to the eigenvalue  $\lambda = -3$  in (42), and  $v_2$  is a solution of linear system

$$(A - \lambda I)v = v_1. \tag{44}$$

Solving the system in (44) we obtain a solution

$$v_2 = \begin{pmatrix} 1/4 \\ 0 \end{pmatrix}. \tag{45}$$

We then obtain the general solution for the system in (40):

$$\begin{pmatrix} x(t) \\ y(t) \end{pmatrix} = (c_1 e^{\lambda t} + c_2 t e^{\lambda t})v_1 + c_2 e^{\lambda t}v_2, \tag{46}$$

where  $v_1$  is given in (43) and  $v_2$  is given in (29), and  $c_1$  and  $c_2$  are arbitrary constants.

A sketch of the phase portrait of the system in (40) is shown in Figure 6 on page 18. The sketch shows also the nullclines and the directions of the trajectories on the nullclines.  $\square$

9. Let  $u$  and  $v$  be two nonnegative continuous functions defined on some open interval  $J$  which contains  $t_o$  and that

$$u(t) \leq M + \int_{t_o}^t v(\tau)u(\tau) \, d\tau \tag{47}$$

for all  $t \in J$  and some nonnegative constant  $M$ . Show that

$$u(t) \leq M e^{\int_{t_0}^t v(\tau) d\tau} \quad \text{for all } t \in J. \quad (48)$$

(*Suggestion:* Let  $\varphi(t) = M + \int_{t_0}^t v(\tau)u(\tau) d\tau$  and show that  $\varphi$  is a solution to certain initial value problem for a linear first order equation.)

**Solution:** Let

$$\varphi(t) = M + \int_{t_0}^t v(\tau)u(\tau) d\tau, \quad \text{for all } t \in \mathbb{R}. \quad (49)$$

Thus, using the Fundamental Theorem of Calculus,

$$\varphi'(t) = v(t)u(t), \quad \text{for all } t \in \mathbb{R}. \quad (50)$$

It also follows from (49) that

$$\varphi(t_0) = M. \quad (51)$$

Now, use the assumption that  $u$  and  $v$  are nonnegative and the estimate in (47) to obtain from (50) that

$$\varphi'(t) \leq v(t) \left( M + \int_{t_0}^t v(\tau)u(\tau) d\tau \right), \quad \text{for all } t \in \mathbb{R},$$

which, in view of (49), can be rewritten as

$$\varphi'(t) \leq v(t)\varphi(t), \quad \text{for all } t \in \mathbb{R}. \quad (52)$$

Next, rewrite the inequality in (52)

$$\varphi'(t) - v(t)\varphi(t) \leq 0, \quad \text{for all } t \in \mathbb{R},$$

and multiply by the integrating factor

$$\mu(t) = e^{-\int_{t_0}^t v(\tau) d\tau}, \quad \text{for all } t \in \mathbb{R}, \quad (53)$$

to obtain that

$$\mu(t)\varphi'(t) - v(t)\mu(t)\varphi(t) \leq 0, \quad \text{for all } t \in \mathbb{R}, \quad (54)$$

where we have used the fact that  $\mu(t) > 0$  for all  $t$ .

Note that from (53) we obtain that

$$\mu(t_0) = 1, \quad (55)$$

and, using the chain rule,

$$\mu'(t) = -v(t)\mu(t), \quad \text{for all } t \in \mathbb{R}. \quad (56)$$

Next, substitute (56) into (54) to obtain the inequality

$$\mu(t)\varphi'(t) + \mu'(t)\varphi(t) \leq 0, \quad \text{for all } t \in \mathbb{R},$$

which we can rewrite as

$$\frac{d}{dt} [\mu(t)\varphi(t)] \leq 0, \quad \text{for all } t \in \mathbb{R}, \quad (57)$$

by virtue of the Product Rule.

Integrate on both sides of (57) with respect to  $t$  from  $t_o$  to  $t$ , and use the Fundamental Theorem of Calculus to get that

$$\mu(t)\varphi(t) - \mu(t_o)\varphi(t_o) \leq 0, \quad \text{for all } t \in \mathbb{R},$$

or, in view of (51) and (55),

$$\mu(t)\varphi(t) - M \leq 0, \quad \text{for all } t \in \mathbb{R},$$

or

$$\mu(t)\varphi(t) \leq M, \quad \text{for all } t \in \mathbb{R}. \quad (58)$$

Divide both sides of the inequality in (56) and use (53) to get that

$$\varphi(t) \leq M e^{\int_{t_o}^t v(\tau) d\tau}, \quad \text{for all } t \in \mathbb{R}. \quad (59)$$

Finally, use the assumption in (47) and the definition of  $\varphi$  in (49) to conclude that

$$u(t) \leq M e^{\int_{t_o}^t v(\tau) d\tau}, \quad \text{for all } t \in \mathbb{R},$$

which is the assertion in (48).  $\square$

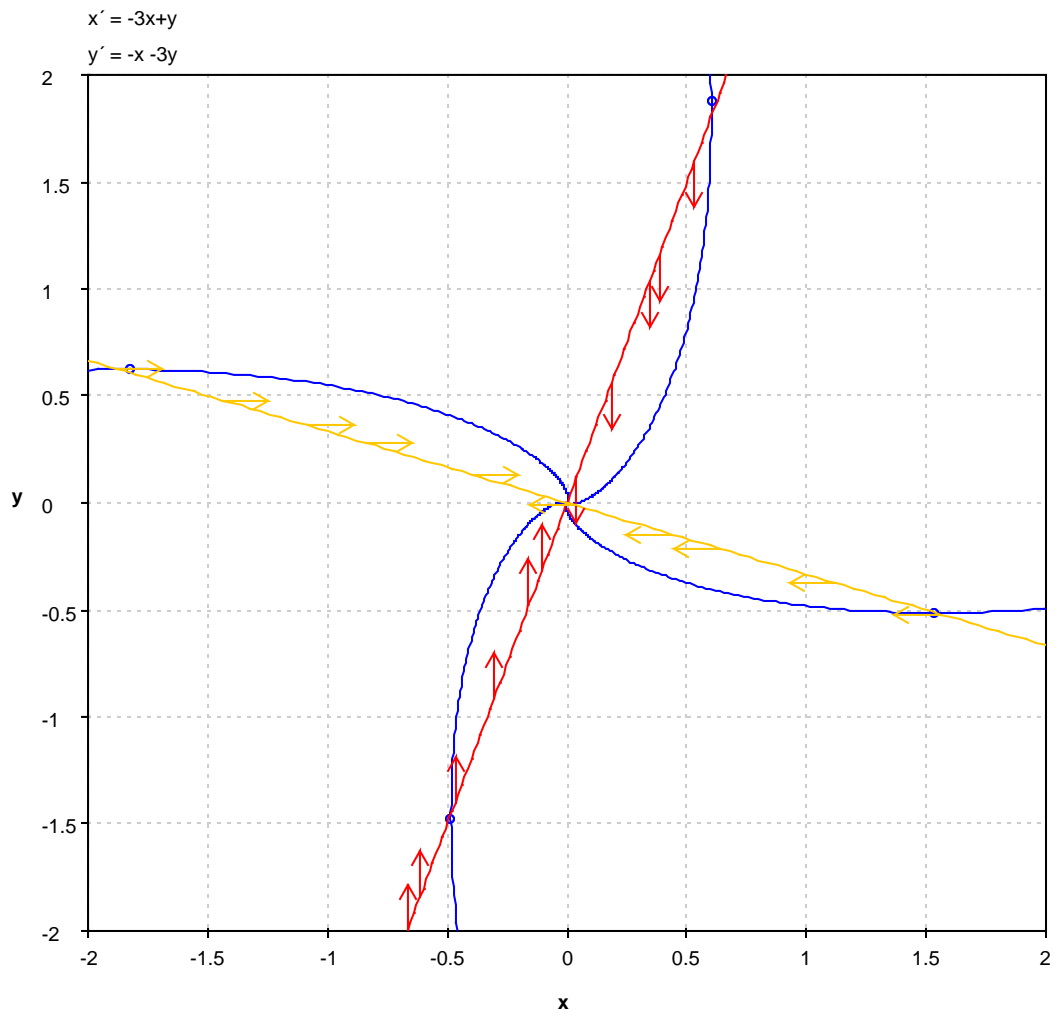

Figure 4: Sketch of Phase Portrait of System (22)



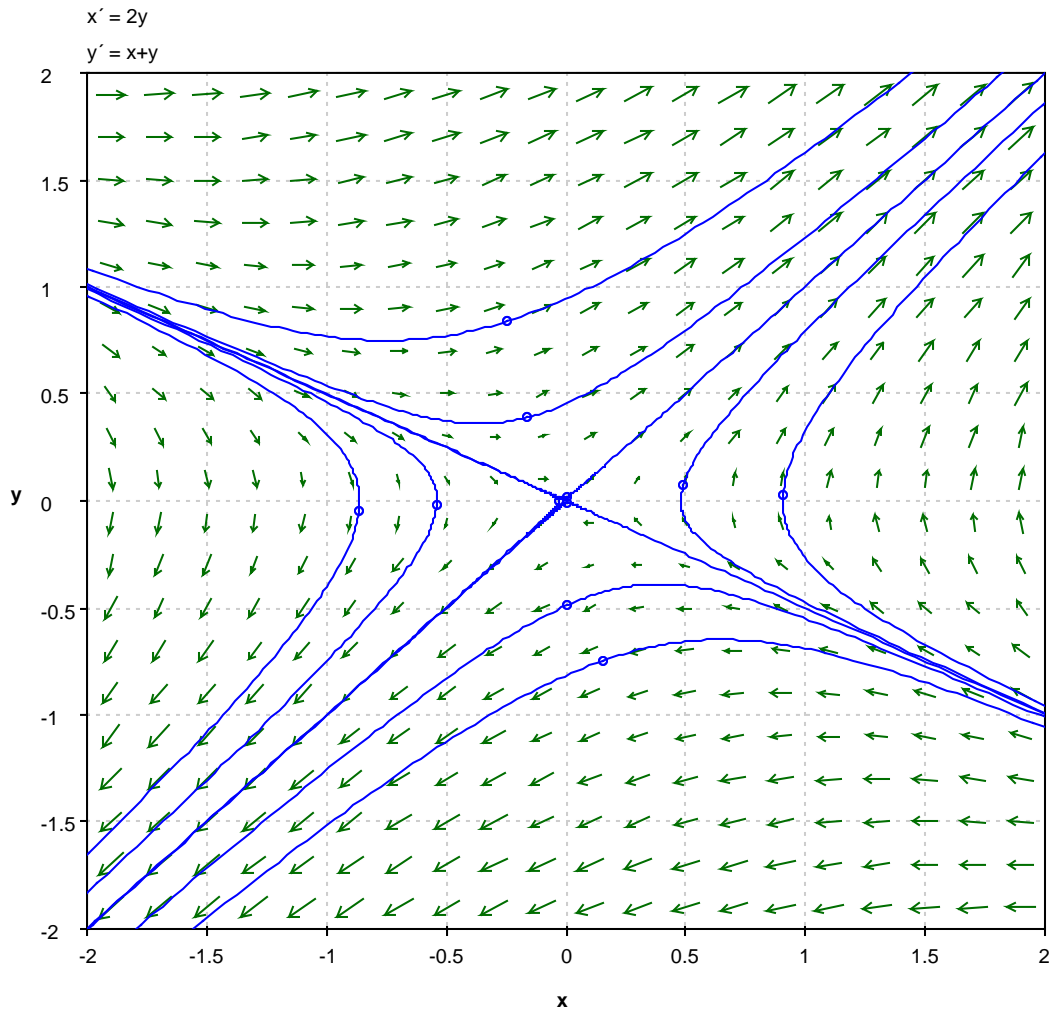

Figure 5: Sketch of Phase Portrait of System (25)

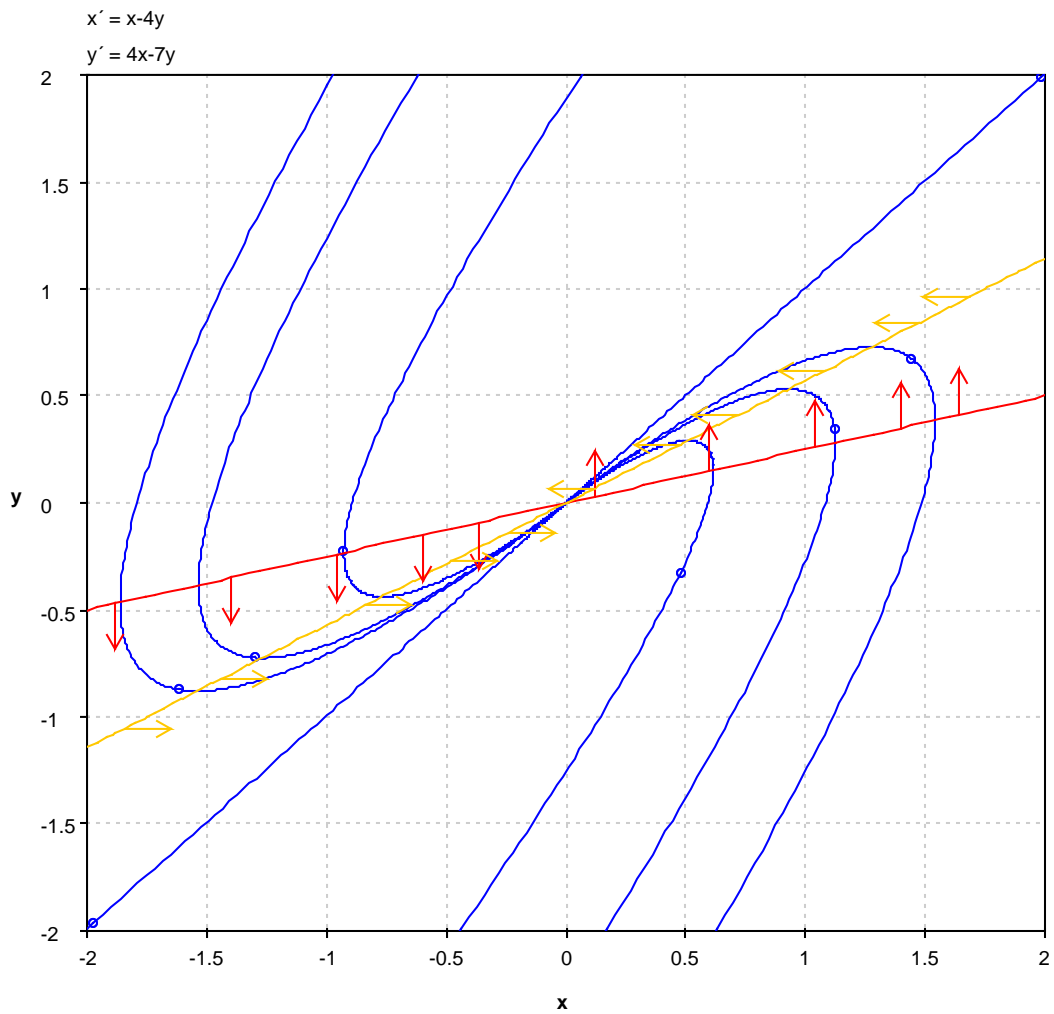

Figure 6: Sketch of Phase Portrait of System (40)